



台灣百大品牌  
大田精密工業股份有限公司  
O-TA PRECISION INDUSTRY CO., LTD.



台灣百大品牌 TOP 100 TAIWAN BRANDS 中國名牌第一

# 大田精密工業股份有限公司

股票代號：8924

## 法人說明會

鍾政義協理(報告人)

李忠穆協理(Q&A)

★投資人關係聯絡人:

發言人\_鍾政義協理(Chengyi Chung) E-mail : chungyi@o-ta.com.tw TEL:+886-8-7783855#125

代理發言人\_李忠穆協理(Chris Lee) E-mail : chrislee@o-ta.com.tw TEL:+886-8-7783855#298

2023年3月17日



**ALLTAS** Stainless Excellence  
不銹鋼水龍頭精品





# 大綱

公司介紹

營運實績

產業概況

未來發展

O-TA **Design**  
研發力 | 生產力 | 軟實力

★ est. 1988 ★

MANAGEMENT R & D IDEA TECHNOLOGY

創新設計 | 品質至上 | 永續經營

www.o-ta.com.tw

屏東縣內埔工業區建富路8號  
(No.8 Chien-Fu Rd, Nei-Pu Industrial Zone, Pingtung County, R.O.C)  
Phone : +886-8-778-3855 Fax : +886-8-779-2922





# 公司介紹

- 成立日期：1988年7月
- 資本額：NT\$ 8.38億元
- 董事長：李孔文先生
- 副董事長：林忠謙先生
- 總經理：許戎民先生
- 主要業務：
  - ✓ 高爾夫球頭及球具之製造、委外加工、裝配及銷售。
  - ✓ 自行車品牌成車與車架銷售
  - ✓ 水五金ALLTAS
  - ✓ 新創設計
- 天下雜誌1000大企業排名之上櫃績優公司
- 中華徵信所台灣地區企業TOP5000排名之績優公司
- 上櫃日期：2000/02/09 (股票代號8924)
- 公司地址：台灣.屏東縣內埔鄉豐田村建富路8號
- 工廠位置：江西大田:江西/贛州；領航:廣東/惠州





# O-TA GOLF Design

研發力 | 設計力 | 生產力



誠信務實  
Honesty Pragmatic



研發創新  
Innovative R & D

ESG

● 環境保護

● 社會責任

● 公司治理



永續經營  
Sustainable Operation

# 永續經營



大田精密工業股份有限公司  
O-TA PRECISION INDUSTRY CO., LTD.



我們的願景

追求永續經營環境，成為最有創意的  
民生日用精品與運動器材公司，  
為客戶、員工、股東及社會大眾  
創造最大價值及最佳服務。



ALLTAS Stainless Excellence  
不鏽鋼水龍頭精品



OTAMADE  
GOODNESS IN LIFE



# O-TA 大田事業群

競爭力~從核心擴充~**持續創新**





# 我們的客戶 Our Customers

大田服務多元化的客戶，提供客戶OEM/ODM/IDM等多元服務，與客戶協同設計，提供創新產品！



**PXG**、**TITLEIST**、TOUR EDGE ...



**AKIRA**、**BRIDGESTONE**、HONMA、JAPANA、KASCO、MAJESTY  
、**MITSUBISHI**(shaft-Diamana)、**MIZUNO**、ROMARO、TSURUYA  
、YAMAHA、YONEX...







# 大田的優勢

**\*不斷創新出產品的附加價值，營造在市場上無可取代的地位!**

**以客戶為導向，提供客戶「專屬」之「一次購足」服務!**

**服務多元化的客戶，應變能力強!**

- ✓彈性的EPS 快速生產系統
- ✓提供客戶專線 專層 專棟生產
- ✓球頭、球桿生產至整套球具組裝的專屬服務
- ✓研發實力堅強 客戶安心將產品交給大田生產!
- ✓營運管理能力強!

**{設計[(製造)服務]}**



# 產品技術發展歷程 (球頭→複材運動器材→新創產品)

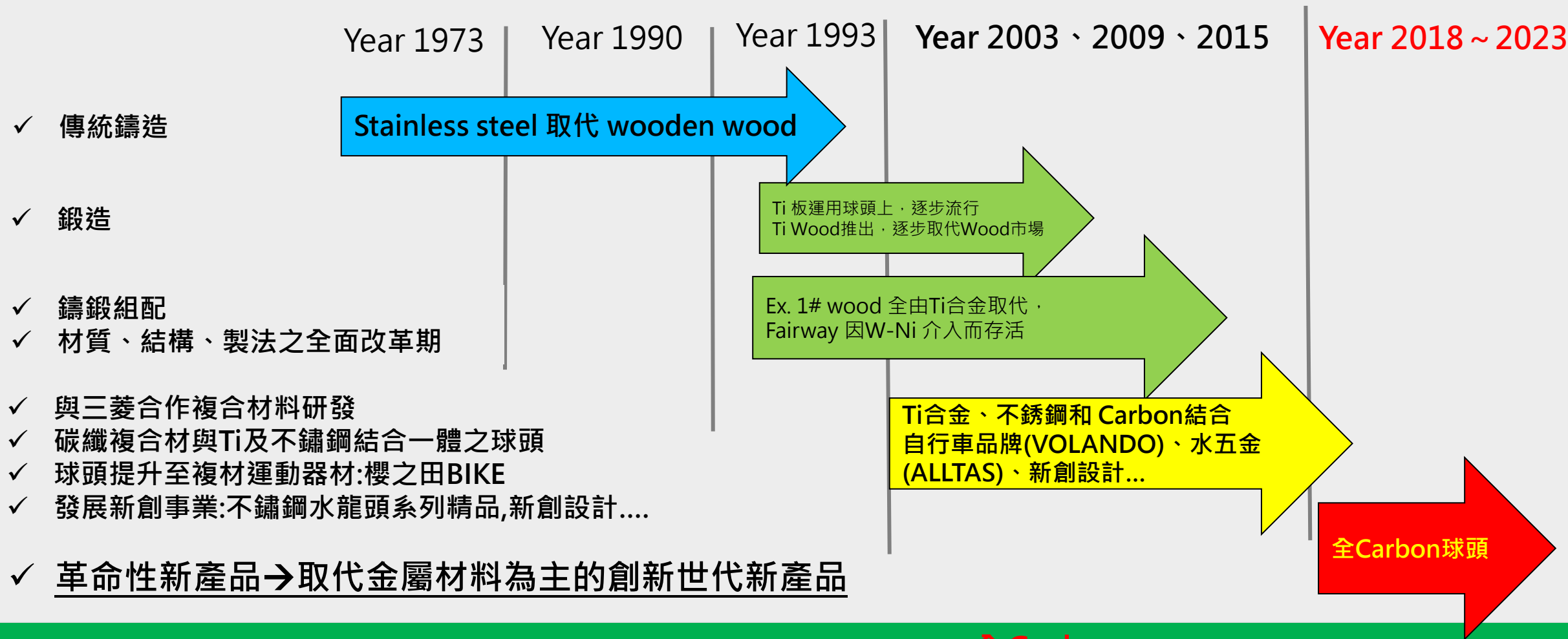

- ◆ 不銹鋼鑄造→鈦合金鑄造 → 鍛造 → 鑄鍛合一 → Ti合金、不銹鋼和 Carbon 結合 → **全Carbon**
- ◆ 球桿(Shaft) → 組桿 → **One- Stop Shopping**
- ◆ 發展複合材料 → Hockey stick、BIKE、其他複合材料運動器材





LS-DYNA USER INPUT  
Time = 0

## Simulation for COR

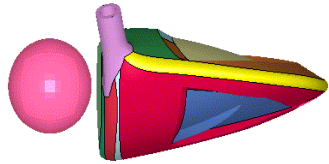

### COR 模擬



LS-DYNA USER INPUT  
Time = 0  
Contours of Maximum Principal Stress  
max ipt. value  
min=0, at elem# 1  
max=0, at elem# 1

## Simulation for Stress

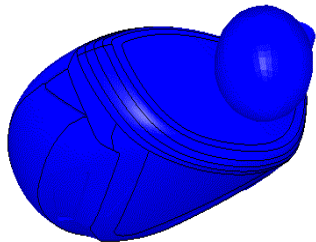

### 應力模擬

Fringe Levels

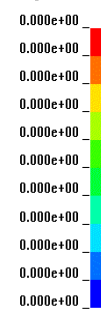

## Simulation for Vibration

LS-DYNA eigenvalues at time 1.00000E-0  
Freq = 1883.1  
Contours of Resultant Displacement  
min=0.0232859, at node# 74938  
max=8.92164, at node# 83367

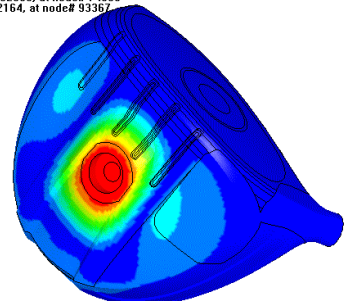

Fringe Levels

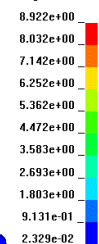

### 模態振動模擬

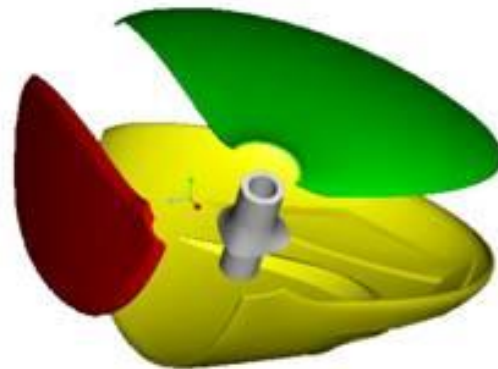
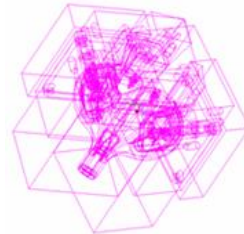
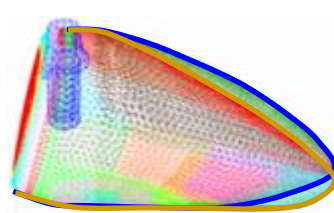
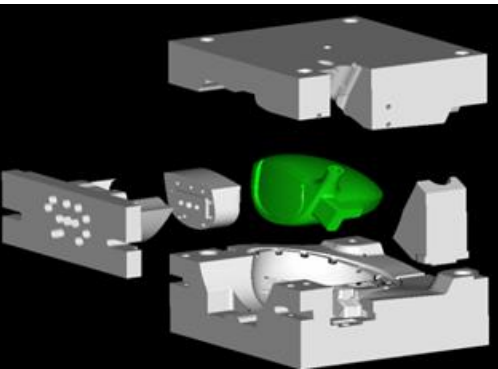

# 研發創新~球頭CAD/CAM ; CAE Computer Aided Engineering (CAE) on Golf Head

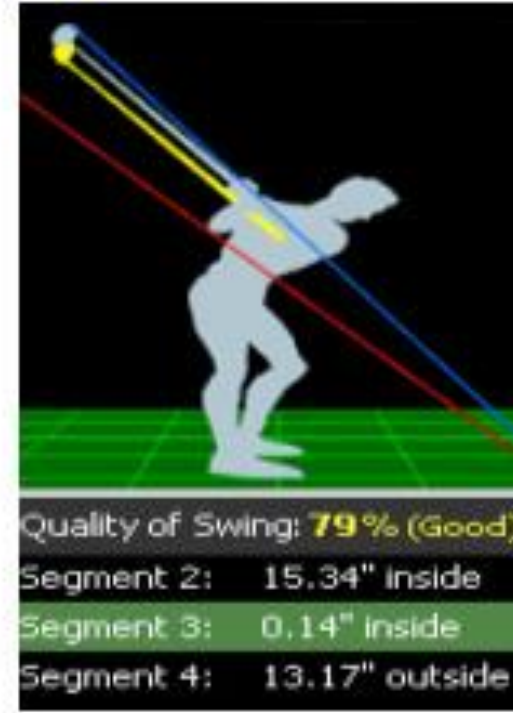
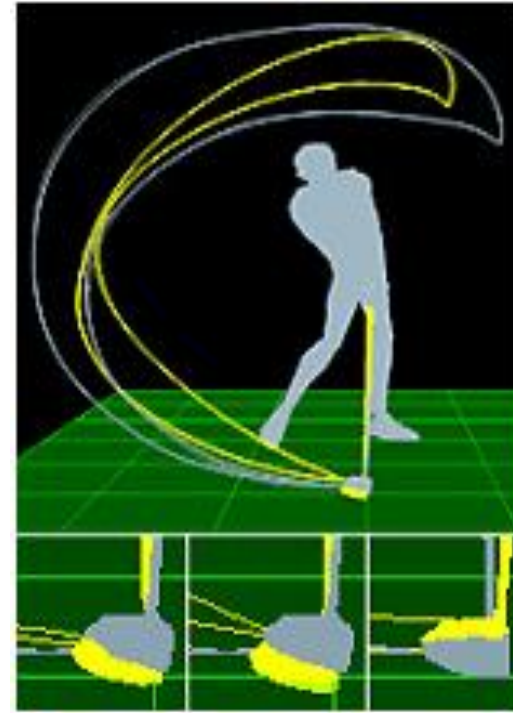
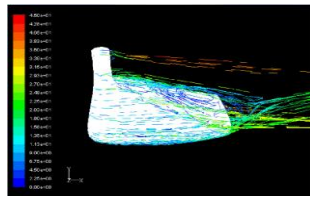



# 人因工程分析

大田的球頭開發設計，包括CAD (Computer Aided Design)、RE (Reverse Engineering)、RP (Rapid Prototyping)、CAM (Computer Aided Manufacturing)、CAE (Computer Aided Engineering)、ROBOT/Track Man擊球測試...等，都是高水準與高科技的軟硬體結合應用。

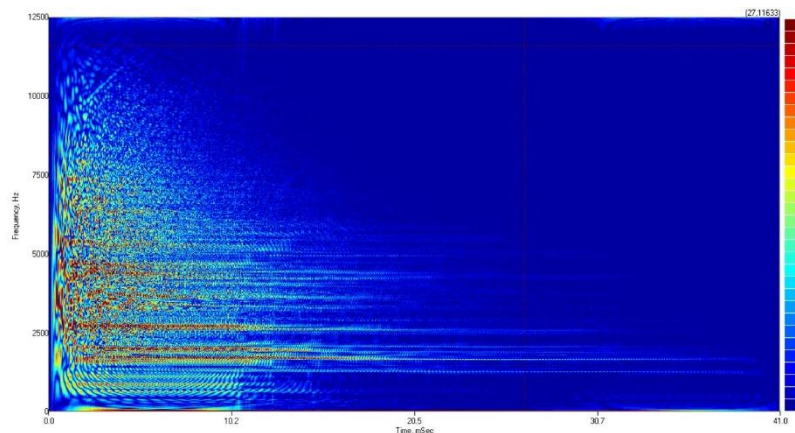
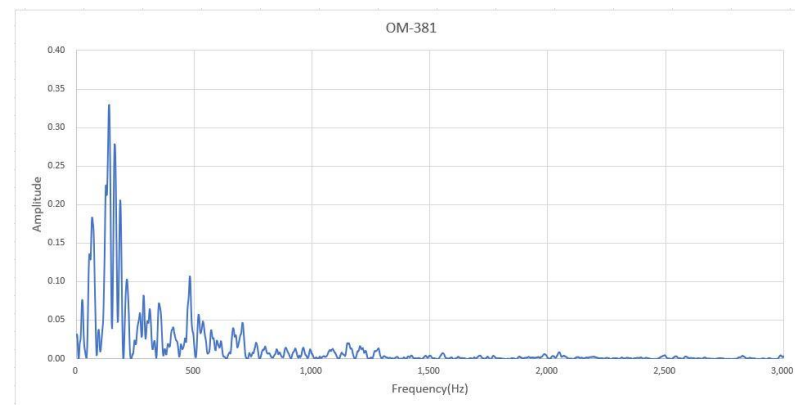
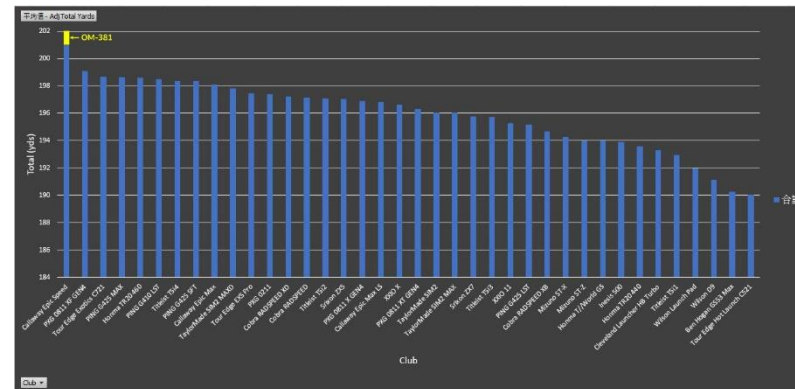
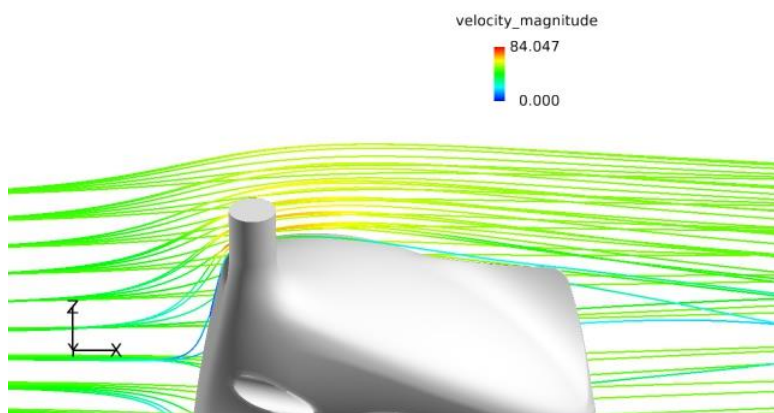
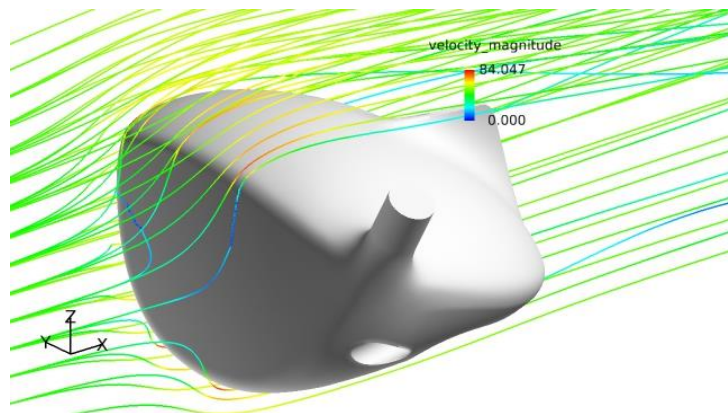



# 高爾夫模擬室

1. 增加球頭測試的完整性，提供多樣數據報告。
2. 增加客人活動選擇多元性。
3. 增進相關設計人員對球頭的認識與性能了解。
4. 推廣高爾夫運動。

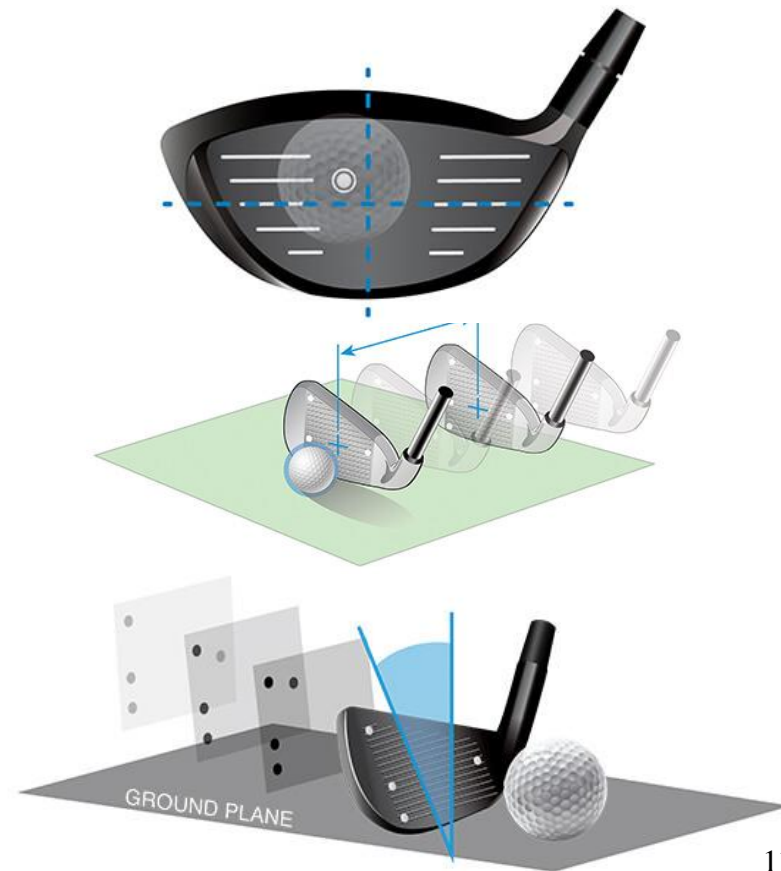
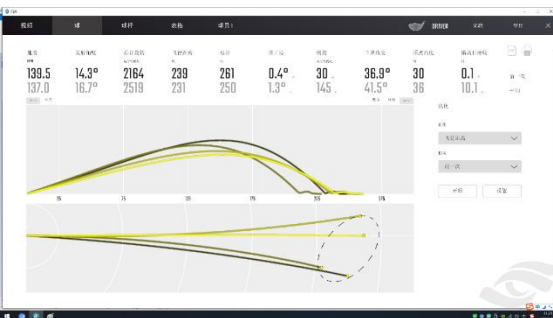

# 最佳球具for高揮桿速度族群

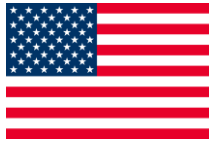

USA



TRUTH DIGEST

## MYGOLFSPY

### BEST DRIVERS FOR HIGH SWING SPEEDS

FEB. 13 2023

## TOP 5 DRIVERS: FORGIVENESS





# Golf Digest

## HOT LIST 2023



USA

### HOT LIST 2023

What's better than getting new equipment? Getting the best clubs for you. The Hot List is here to help.

GO

#### BUILD YOUR PERFECT HOT LIST BAG

A diagnosis of your game will help determine which of the 138 clubs on the Golf Digest Hot List are right for you.

TRY OUR QUIZ

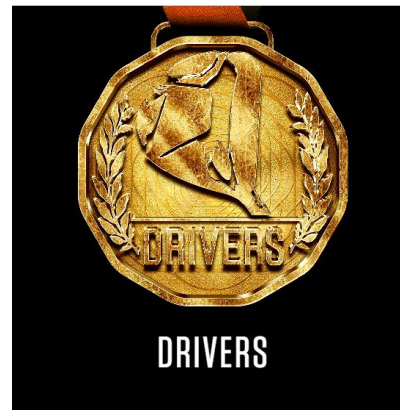

DRIVERS



GOLD



Mizuno ST-Z 230 / ST-X 230 / ST-X 230 PLTNM



SILVER



Tour Edge Exotics C723/E723

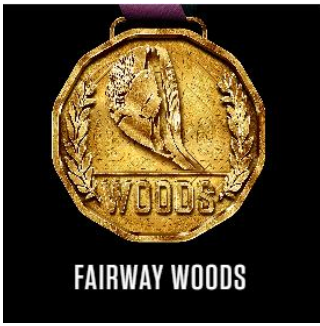

FAIRWAY WOODS

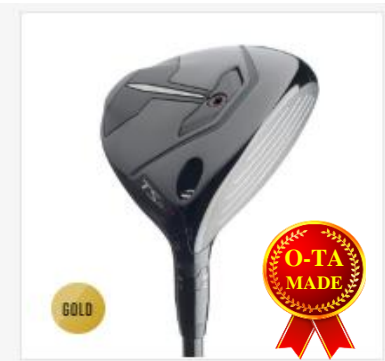

GOLD



Titleist TSR1 / TSR2 / TSR2+ / TSR3

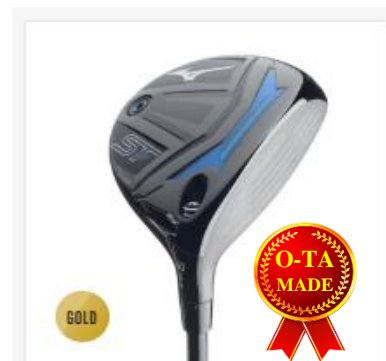

GOLD



Mizuno ST-Z 230

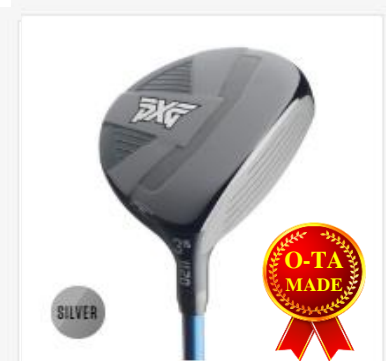

SILVER



PXG 0211



GOLD



Titleist TSR1 / TSR2 / TSR3 / TSR4



SILVER



O211

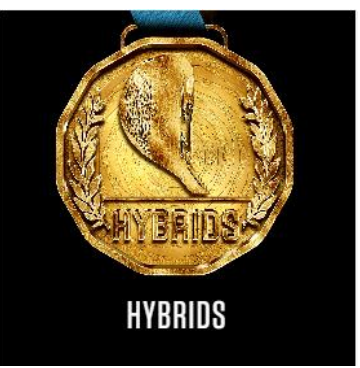

HYBRIDS



SILVER



Mizuno ST-Z 230



SILVER



PXG 0211

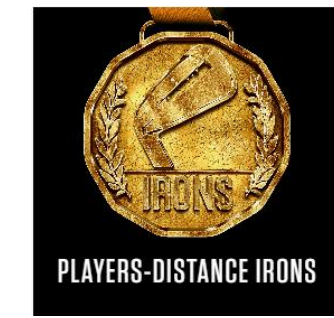

PLAYERS-DISTANCE IRONS



GOLD



Mizuno JPX923 Hot Metal Pro





# Golf Digest

## HOT LIST 2023



USA

### HOT LIST 2023

What's better than getting new equipment? Getting the best clubs for you. The Hot List is here to help.

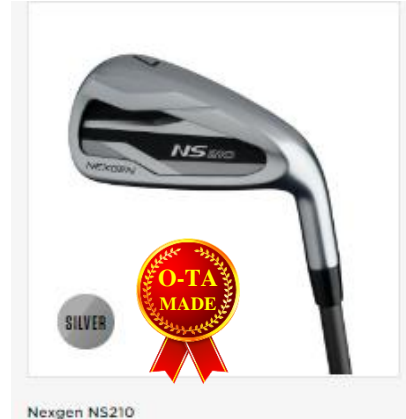
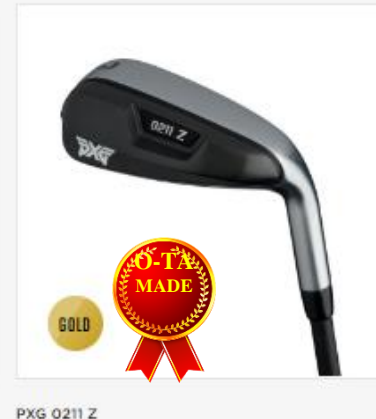
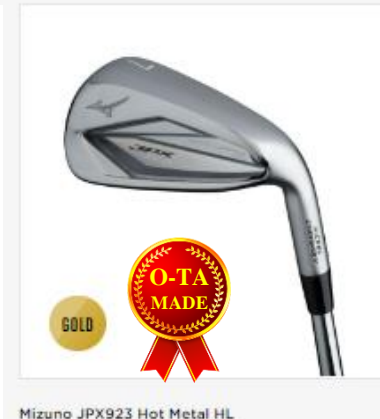
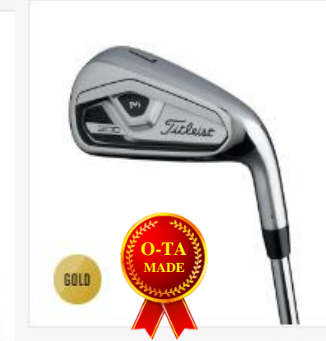
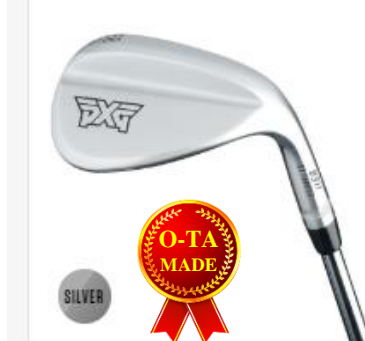
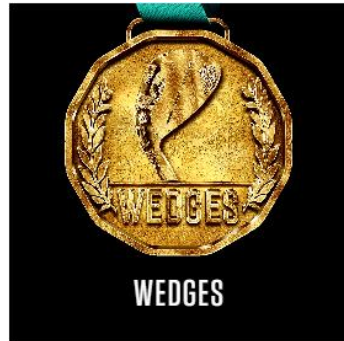
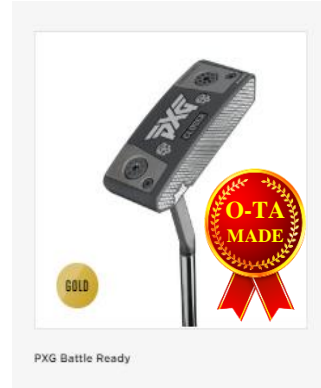
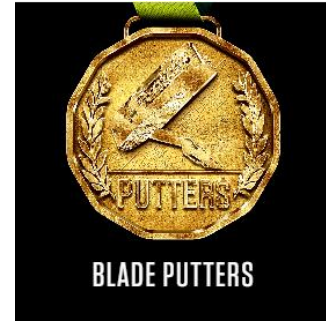
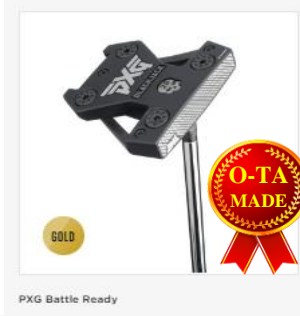
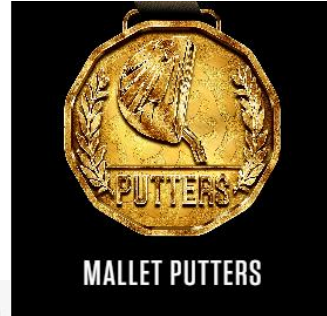
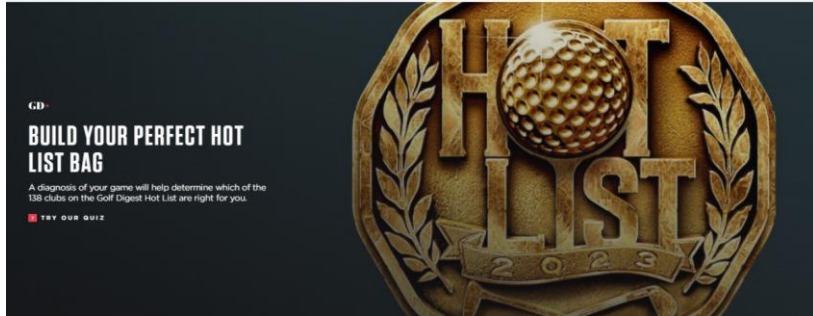



台灣百大品牌  
大田精密工業股份有限公司  
O-TA PRECISION INDUSTRY CO., LTD.



# PXG

PARSONS XTREME GOLF







# PXG

PARSONS XTREME GOLF







*Titleist*<sup>®</sup>



**TITLEIST IS THE #1 BALL, DRIVER, HYBRID, UTILITY IRON, IRON, AND WEDGE AT THE OPEN CHAMPIONSHIP**

**70%**  
GOLF BALLS  
NEAREST COMPETITOR **14%**

**31%**  
DRIVERS  
NEAREST COMPETITOR **26%**

**36%**  
HYBRIDS  
NEAREST COMPETITOR **32%**

**35%**  
UTILITY IRONS  
NEAREST COMPETITOR **23%**

**28%**  
IRONS  
NEAREST COMPETITOR **21%**

**43%**  
WEDGES  
NEAREST COMPETITOR **18%**



# Titleist







**B**  
**BRIDGESTONE**  
**GOLF**

右に逃さず、  
つかまえて飛ばす。

**B2**

右に逃さず、  
つかまえて飛ばす。

**B2**



第3の「B」、現る。

「**B**」  
「**B**」  
「**B**」  
新。

左を恐れず、  
狙って飛ばす。

**B1**



**B1、B2、誕生。**

圧倒的な飛びと直進性、しかも、やさしく。  
今、ドライバーショットに求められる絶対条件を、  
すべてのゴルファーへ。



古江彩佳  
LPGA 蘇格蘭 公開賽冠軍

すべてのゴルファーへ。





台灣百大品牌  
大田精密工業股份有限公司  
O-TA PRECISION INDUSTRY CO., LTD.



O-TA的客戶





# 極致的鑄造工藝 鑄造鉻鉬鋼



<https://www.youtube.com/watch?v=IPq7241Llg8>





**JPX  
FLI-HI**

ウェーブテクノロジーソールが  
コアエアを拡大  
ミスヒット時の  
初速のロスを防ぎます。

ミスヒット時の初速のロスを防ぎます。

<https://www.youtube.com/watch?v=IPq7241LIg8>

**JPX  
FLI-HI**

**JPX FLI-HI 飛距離マップ**

ドライバーヘッドスピード130~140m/s 40℃以上での使用を想定しています。

ヘッドスピード (m/s)	No. 7	No. 8	No. 9
130	81	85	89
140	83	87	91
150	85	89	93
160	87	91	95
170	89	93	97
180	91	95	99
190	93	97	101
200	95	99	103

ヘッドスピード (m/s)	No. 7	No. 8	No. 9
130	29	26	23
140	29	26	23
150	29	26	23
160	29	26	23
170	29	26	23
180	29	26	23
190	29	26	23
200	29	26	23

ラインナップは、20度から29度まで3度刻みの4番手です。





## O-TA的客戶

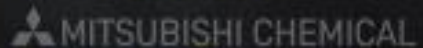

曾與日本三菱公司合資  
在深圳成立三田高爾夫用品(深圳)有限公司  
生產頂級碳纖維高爾夫球桿，  
包括老虎伍茲所使用的球桿。  
多年來持續與三菱合作，  
頂級碳纖球桿品質深獲青睞。

## DIAMANA



DIAMANA® SERIES







# O-TA江西大田廠(江西省贛州市)

## 已建立的長期競爭優勢彰顯效益

- 深耕大陸量產基地
- 打造智慧工廠\_智能自動化
- 新廠房即將擴產
- 固本精實、創新突破

掌控核心技術  
穩定&提升製程能力  
合理化、自動化、科技化、省力化







# 江西大田\_贛州\_ **已建立的長期競爭優勢**

- ➡ 穩定的人力資源、充足的電力、天然氣...等
- ➡ 已完備週邊供應鏈
- ➡ 享有大陸政策下的企業優惠：
  - ✓ 照顧外銷型的企業來減少中美貿易的衝擊  
(例如:贛州當地企業所得稅15%,出口退稅,社保降低...等)
- ➡ 聚焦成本管理 & 技術管理



# 智能自動化實績

- 研磨自動化
- 自動浸漿、自動大切、自動磨澆口、自動焊接、自動研磨、自動塗裝...

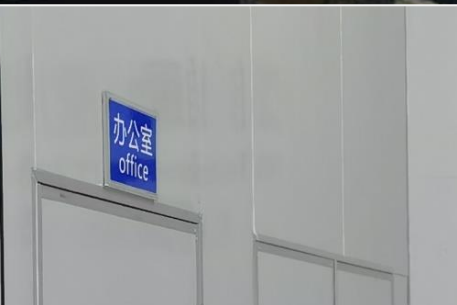
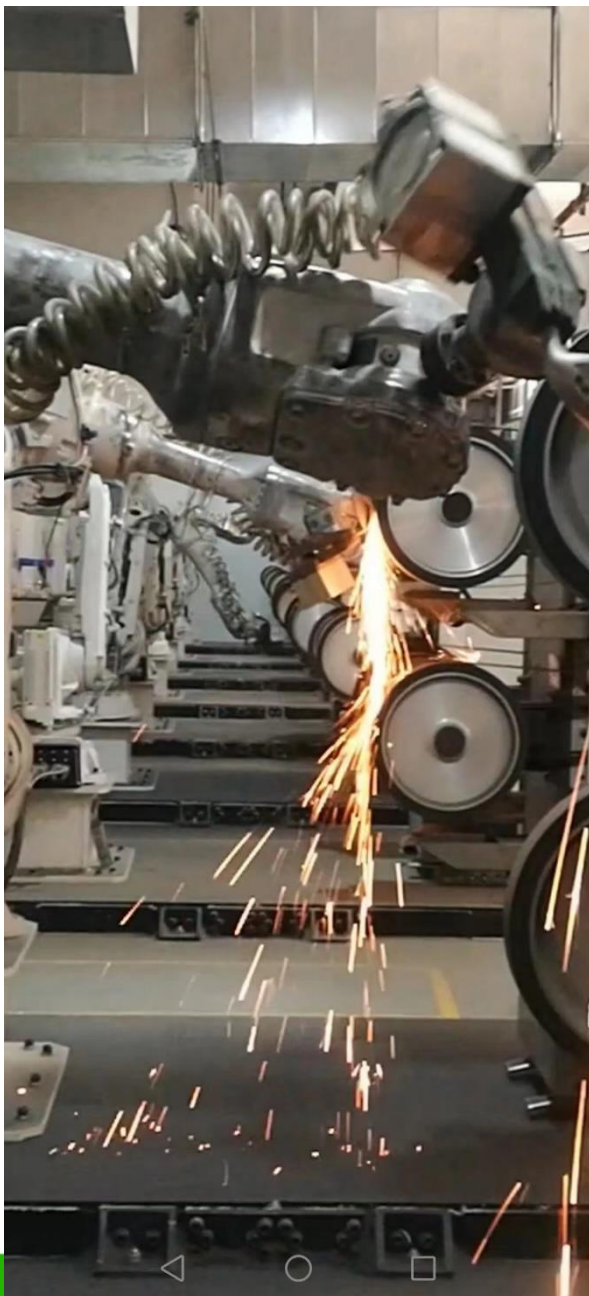

**自動化歡迎您!**  
Welcome to automation!  
自動化へようこそ!





A photograph of a large industrial robotic arm with a white protective covering, positioned in a factory environment. The arm is extended towards the right side of the frame. The background shows industrial equipment and a clean, well-lit workspace.

# 自動化效益

※降低生產成本，解決缺工問題

※製程穩定，確保品質，提升製造效率與效能

✓ 提升良率與效益的實例分享：

## 自動製殼模系統

- 胚件品質穩定、良率提升，
- 降低勞力負荷
- 作業品質維持一致品質標準
- 製程穩定，品質穩定，利於後段製程
  - 良率高的鑄造胚件，利於後段加工研磨作業，減少研磨量、減少胚件不良返修、降低研磨成本、提高效率...等

未來：加深全流程自動化程度與突破技術能力



# 江西大田的榮譽





# 高爾夫球產學合作與捐贈自行車活動

產學合作 & 在地永續

\*2022/11/17與屏東大學

產學合作暨策略聯盟

\*捐贈精品自行車活動,例如:

12/28屏東大學

12/30屏東科技大學...







**ALLTAS** Stainless Excellence  
不鏽鋼水龍頭精品



安心·水資源



愛心·關懷您



用心·綠環保

Save, Water Resources

Love, Care for you

Living, Green Promotion







# ALLTAS Stainless Excellence

不鏽鋼水龍頭精品

無鉛龍頭。安心選擇 居家×設計×樂事分享

嚴格採用  
食品級 304 不銹鋼  
符合國家標準



WWW.ALLTAS.COM.TW



品質至上

創新設計

健康傳承

永續經營

安心首選

**無鉛無毒** 飲水用水龍頭  
全國首家通過經濟部標準檢驗局應施檢驗  
R74267 飲水用水龍頭性能試驗100%合格廠商！



安心·水資源



愛心·關懷您



用心·綠環保



台灣百大品牌  
大田精密工業股份有限公司  
O-TA Precision Industry CO.,LTD.

台灣總部: 台灣屏東縣內埔工業區建富路8號  
展示中心: 台北市中山區長安東路二段81號6樓  
江西廠: 江西省贛州市開發區黃金大道61號

台灣: +886-2-2501-2198  
聯絡人: 客服人員  
電子郵件: twn.service@o-ta.com.tw

中國大陸: +86-797-213-9988 ext: 3811  
電子郵件: alltas@jxota.com.cn



領航複材科技(惠州)有限公司  
VGT COMPOSITE TECHNOLOGY(HUIZHOU)CO., LTD.



大田精密工業股份有限公司  
複材事業部

領航復材科技(惠州)有限公司

公司簡介



複材技術運用  
專業設計與製造廠



## <大田複材事業部-領航公司介紹>

- 成立日期：2018年3月；正式運營 2020年03月

- 資本額：US\$ 400 萬元

- 董事長：李孔文先生

- Team Leader：陳文祥 (台大複材博士)

- 主要業務：

- ✓ 碳纖維電動自行車(e-Bike)車架/前叉 等配件之設計、製造及銷售。

- ✓ 碳纖維傳統避震/越野/公路等自行車車架/前叉/車手把/座墊柱等配件之設計、製造及銷售。

- ✓ 複合材料工業用配件(輪圈/Robot Arm...)之設計、製造及銷售。

- ✓ 複合材料運動器材配件(冰曲/草地曲棍等)之設計、製造及銷售。

- 總公司地址：台灣.屏東縣內埔鄉豐田村建富路8號

- 工廠位置：惠州市惠陽區沙田鎮安泰達科技園 領航複材科技有限公司

Sales Ratio of Main Products

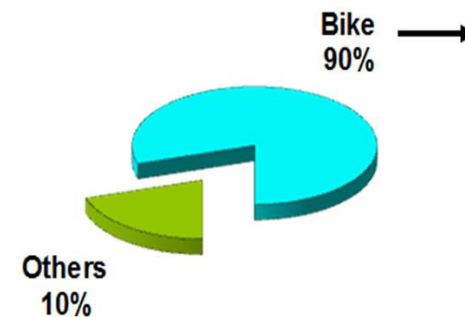

Sales Ratio(Area) of Composite Cycling Parts

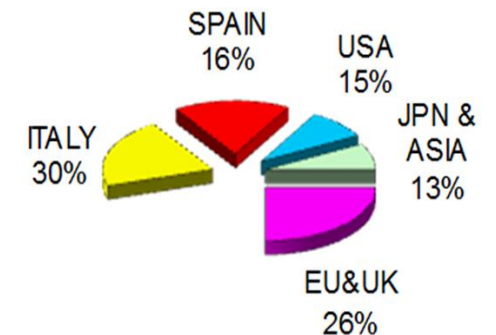

### ◎VGT複合材料核心技術能力:

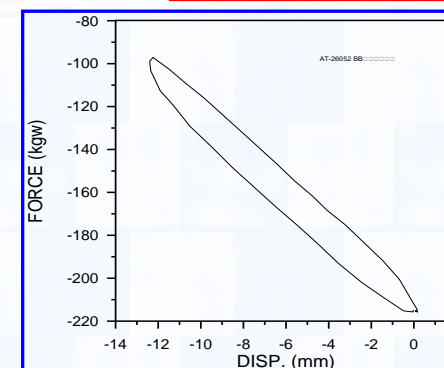
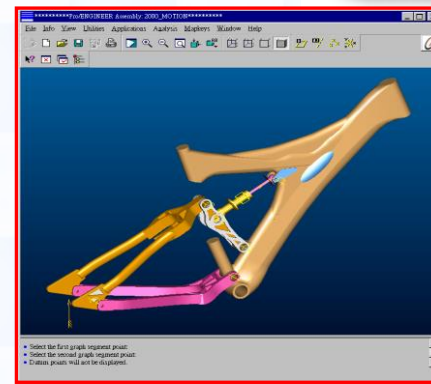
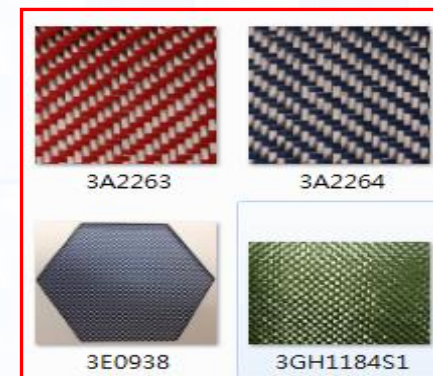
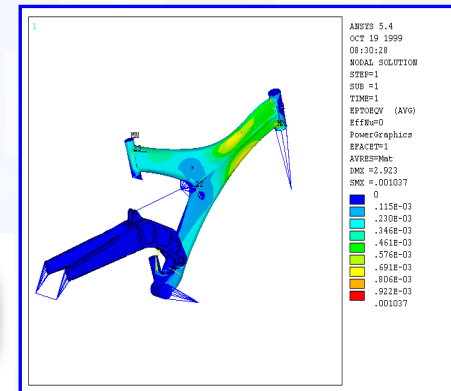





(從櫻之田到領航的技術進展)  
**VGT TECHNOLOGIES**

年度 Year	車架產品重量 Weight (gram) Road Frame	新製程/新技術 Technology	新材料構造 Composite Materials	★特殊成就 Achievement
2003-2005	1,200 grams	Bladder Molding Process/吹氣	24T/T700	*西班牙第一大客戶各車種量產成功
2006-2010	1,000 grams	Bladder Molding Process+/吹氣+	24T/T700 + 30T/T800	*2007年UCI世界冠軍 *2008年奧運冠軍
2011-2013	850 grams	BMP+PU Shell /吹氣+PU殼	30T/T800 + 46T/M46JB	*義大利第一大品牌輕量車架Cento Uno問世
2014-2018	700 grams	BMP+EPS+PU /吹氣+EPS+PU	30T + 46T + 65T	*義大利第一大品牌NDR智慧避震車問世
2019-2020	<b>600 grams</b>	<b>EPUS</b> /吹氣+抽真空+乳膠+EPS+PU	30T + 33T + 46T + 80T	*各客戶碳纖維e-Bike問世
<b>2021-2023</b>	<b>Super Lite Suspension e-bike (less than 1.5 kgs)</b>	<b>EPSPULX2/Advanced EPS+PU+LATEX+Vaccum Process</b>	30T + 33T + 46T + Pitch Super High Modulus	*Bike of the year 2022 in Japan

## ⊕世界知名品牌的客戶群

✓ EU   

✓ WILIER 、 ORBEA 、 DE ROSA 、 CARRERA 、 DT-SWISS  
、 GPRAG 、 CINELLI 、 MSC 、 VDB 、 INTERSENS 、  
BATTAGLIN 、 FANTIC 、 GUERCIOTTI ...

✓ JP & US 

✓ BRIDGESTONE 、 PODIUM 、 INTERMAX 、 HATTORI  
✓ IBIS 、 FELT



◎ VGT - Main Products:

碳纖維自行車產品



NEW Composite Electric Bike

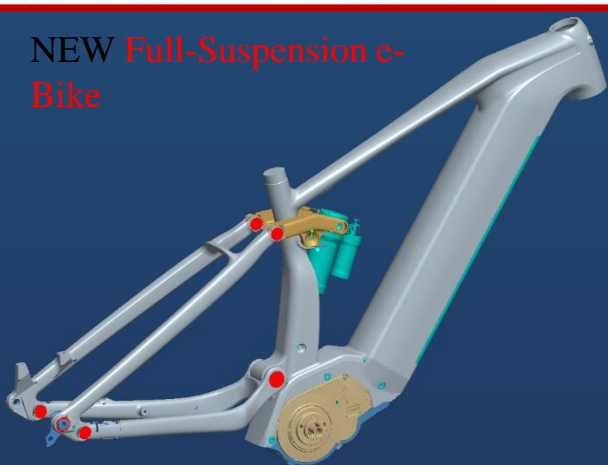

NEW Full-Suspension e-Bike

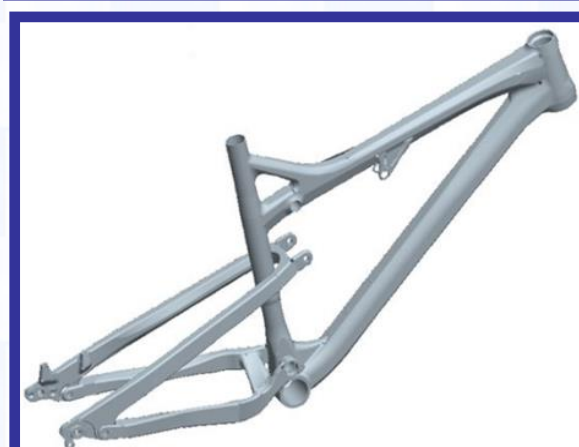

NEW HYBRID Suspension e-Bike

**NEW Lite Full Suspension Composite e-Bike**



**\*SUPER LITE  
SUSPENSION e-  
Bike**

**\*FRAME (車架重) -  
--- 1,490 grams**



**NEW Comfortable (Elastomer) Composite Bike**

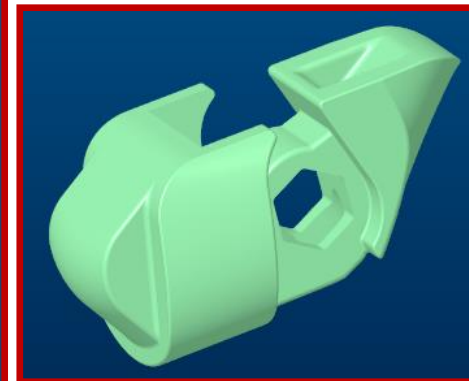
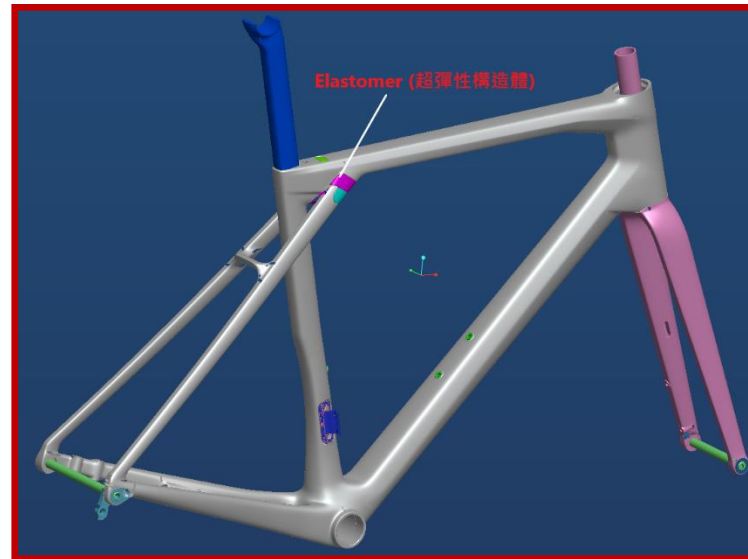

**\*超輕量舒適車(採用  
新材料技術開發出來  
的超彈性構造體)**

**\*New Material &  
Construction ---  
Special Elastomer**





◎Honor Pride: **Bike of the year 2022 in Japan**

Model 1: ANCHOR/RP9 ---- BSC (JAPAN)

Model 2: PHIBRA DISC ---- CARRERA (ITALY)





### Ice hockey products

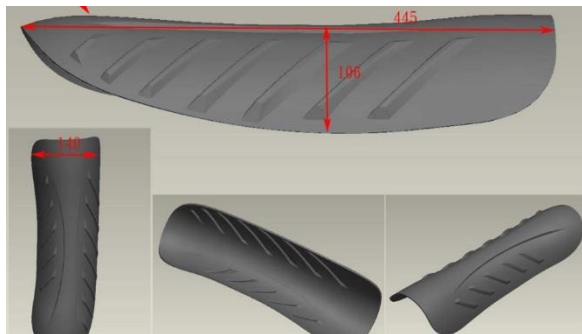

### 3C products



### iPAD B40 Frame



Configuration 4:

Pinching other opposite corners of fiberglass frame.

Bending towards oneself until opposing corners touch

Bending away from oneself until opposing corners touch





\*\*  
EPUS

## <大田複材事業部-領航公司未來發展>

➤ 創新研發(新EPUS製程)

持續精進改善經營績效 強化生產效率與競爭力

➤ 切入汽車-航空絕緣複材/複材輔具/工業用均壓環/AV複材

(Kimball Piano/USA) ◦



車用碳纖製品 (Composite parts for Automobile)



新複合材料製程技術-EPSPULX2

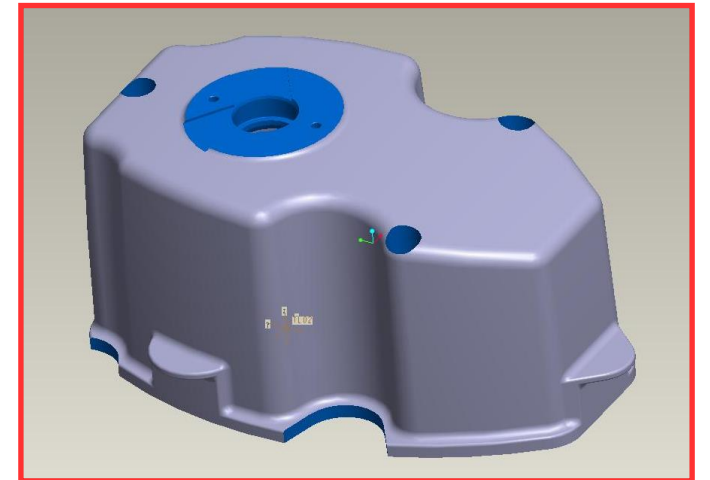

碳纖電機馬達盒  
Composite Case for  
Cylinder Head Cover



# 營運實績





# 大田近五年營運概況

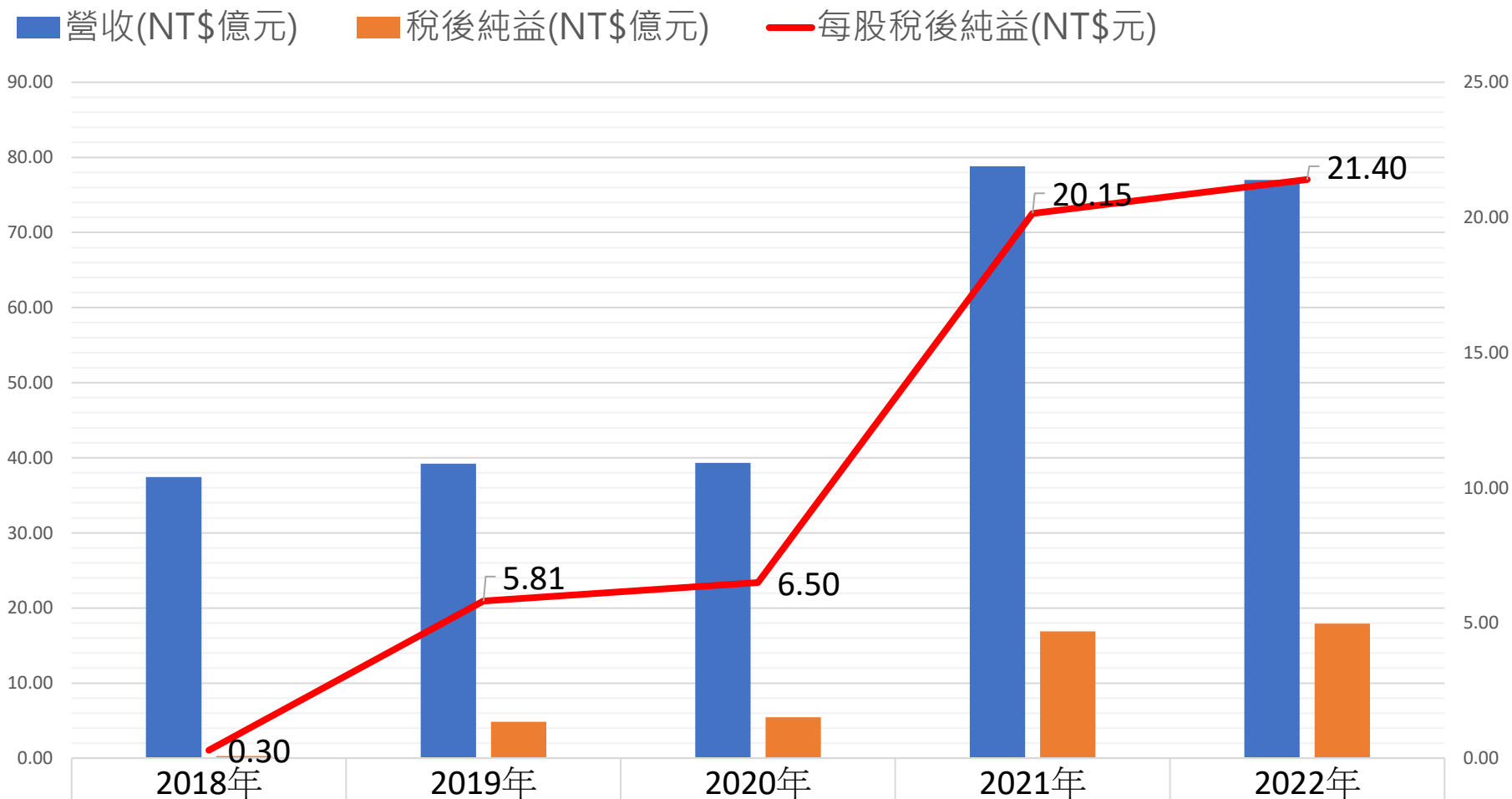

<span style="color: blue;">■</span> 營收(NT\$億元)	37.42	39.21	39.33	78.80	77.00
<span style="color: orange;">■</span> 稅後純益(NT\$億元)	0.31	4.87	5.45	16.88	17.93
<span style="color: red;">—</span> 每股稅後純益(NT\$元)	0.30	5.81	6.50	20.15	21.40



天下雜誌754期Fast 100(快速成長100強)

★2021年大田是~

快速成長營收十強的第5名

快速成長獲利十強的第6名!!!

• 大田精密\_隱型冠軍2.0

- 成立 / 1988年
- 董事長 / 李孔文
- 主要業務 / 高爾夫球頭代工
- 2021年成績 / 營收78.80億元、稅後純益16.88億元
- 2022快速成長一百強排名 / 70
- 隱形冠軍心法 / 專注少量多樣、高附加價值產品；
- 持續投入研發、導入自動化設備。

小金雞豐收、證券大賺

快速成長營收十強

排名	公司名稱	產業別	2021 營業收入 (億元)	快速成長 一百強 排名	2019~21 營收複合 成長率 (%)
1	世紀鋼鐵結構	製造業	99.35	8	103.37
2	采鈺科技	製造業	90.29	34	63.06
3	申豐特用應材	製造業	81.62	45	57.96
4	安聯證券投資信託	金融業	81.40	77	46.84
5	大田精密工業	製造業	78.80	70	48.82
6	力智電子	製造業	59.51	87	45.40
7	嘉威生活	服務業	53.02	21	77.12
8	台新綜合證券	金融業	52.16	81	46.27
9	富世達	製造業	50.20	5	140.90
10	海韻電子工業	製造業	50.18	68	49.61

快速成長獲利十強

排名	公司名稱	產業別	2021 稅後純益 (億元)	快速成長 一百強 排名	2019~21 營收複合 成長率 (%)
1	申豐特用應材	製造業	34.76	45	57.96
2	新加坡商瑞銀證券 台北分公司	金融業	27.21	37	61.19
3	摩根大通證券	金融業	26.36	13	87.40
4	采鈺科技	製造業	21.65	34	63.06
5	台新綜合證券	金融業	17.85	81	46.27
6	大田精密工業	製造業	16.88	70	48.82
7	玉山綜合證券	金融業	16.86	44	58.23
8	第一金證券	金融業	14.96	50	56.33
9	新光證券	金融業	14.79	31	64.22
10	中國信託創業投資	金融業	14.19	9	98.67





# 大田合併損益表 Consolidated Income Statement

幣別：台幣千元(Expressed in Thousands of New Taiwan Dollars, Except for Earnings Per Common Share)	1/1~12/31 (For the Nine Months Ended September 30)				差異 diff.	
	1/1~12/31, 2022		1/1~12/31, 2021			
	金額 Amount	%	金額 Amount	%	金額 Amount	%
營業收入 Operating Revenue	7,700,322	100.0%	7,880,132	100.0%	-179,810	(2.3%)
營業毛利 Operating Margin	2,220,926	28.8%	2,487,575	31.6%	-266,649	(10.7%)
營業費用 Operating Expenses	442,437	5.7%	489,543	6.2%	-47,106	(9.6%)
營業利益 Operating Income	1,778,489	23.1%	1,998,032	25.4%	-219,543	(11.0%)
繼續營業單位本期淨利 Continuing operating income after tax	1,793,142	23.3%	1,690,175	21.4%	102,967	6.1%
停業單位稅後損益 Discontinued operation income	0	0.0%	(3,718)	(0.0%)	3,718	100.0%
本期淨利 Net Income	1,793,142	23.3%	1,686,457	21.4%	106,685	(6.3%)
母公司(損)益 Parent Co. Income (Loss)	1,793,142	23.3%	1,688,279	21.4%	104,863	6.2%
繼續營業單位每股盈餘(元) EPS on continued operations (dollar)	21.40		20.17		1.23	
停業單位每股盈餘(元) EPS on discontinued operations (dollar)	0.00		(0.02)		0.02	
每股盈餘(元) Earnings Per Share (dollar)	21.40		20.15		1.25	



# 營業收入&本期淨利

## Operating Revenue VS Net Income

單位：台幣千元

Unit : NT thousand dollars





# 大田精密8924獲利概況

## O-TA 8924 Profit profile

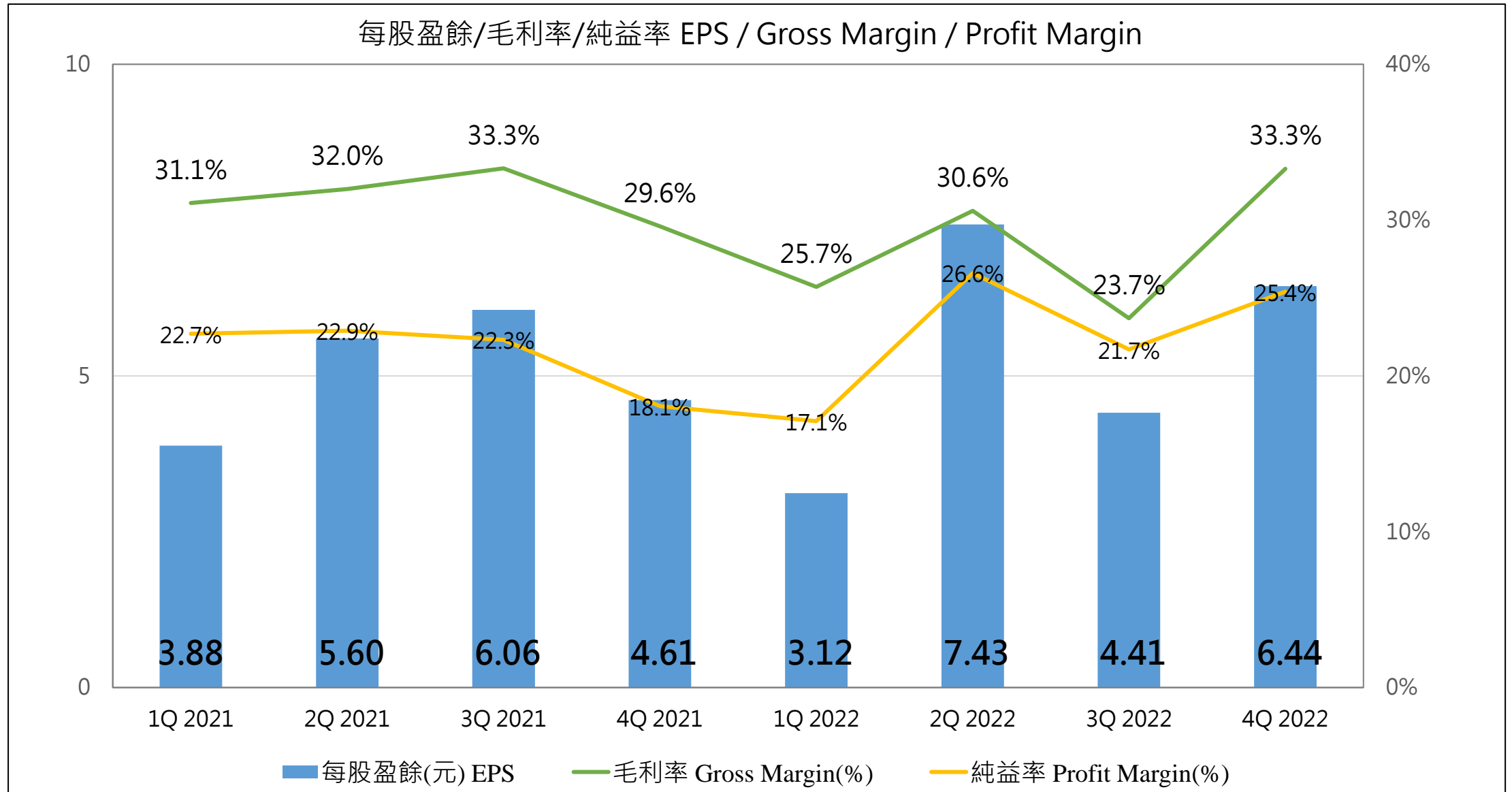

# 2017-2022 EPS and Dividends

## EPS與股利

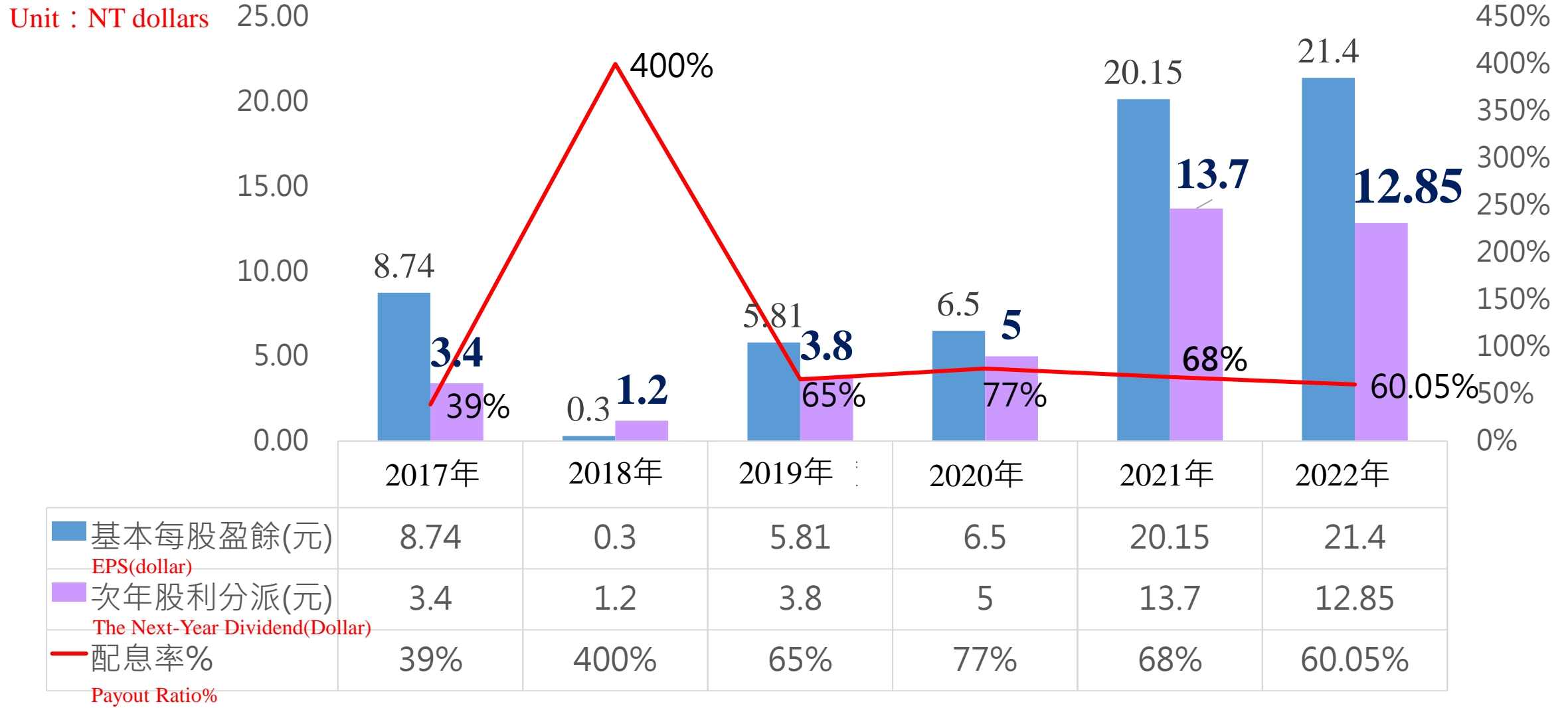





# 產業概況

## • 健康議題，商機無窮

- 根據國際調查機構Plunkett Research研究統計，全球每年的運動休閒相關商機總產值約有1.5兆美元，運動風氣盛行。





# 高爾夫產業動態

➔ 後疫情時代生活型態改變!

✓ **GOLF = 安全健康戶外活動**

✓ **NGF : 2020年Q2起**

**GOLF打球人口結構改變**

➔ 產業重回成長趨勢&良性競爭情勢

➔ 高爾夫重返奧運\_帶動需求

➔ 產品客製差異化、輕量化、多樣少量，更能滿足消費者需求

➔ 新產品生命週期短、各客戶別分散上市時間

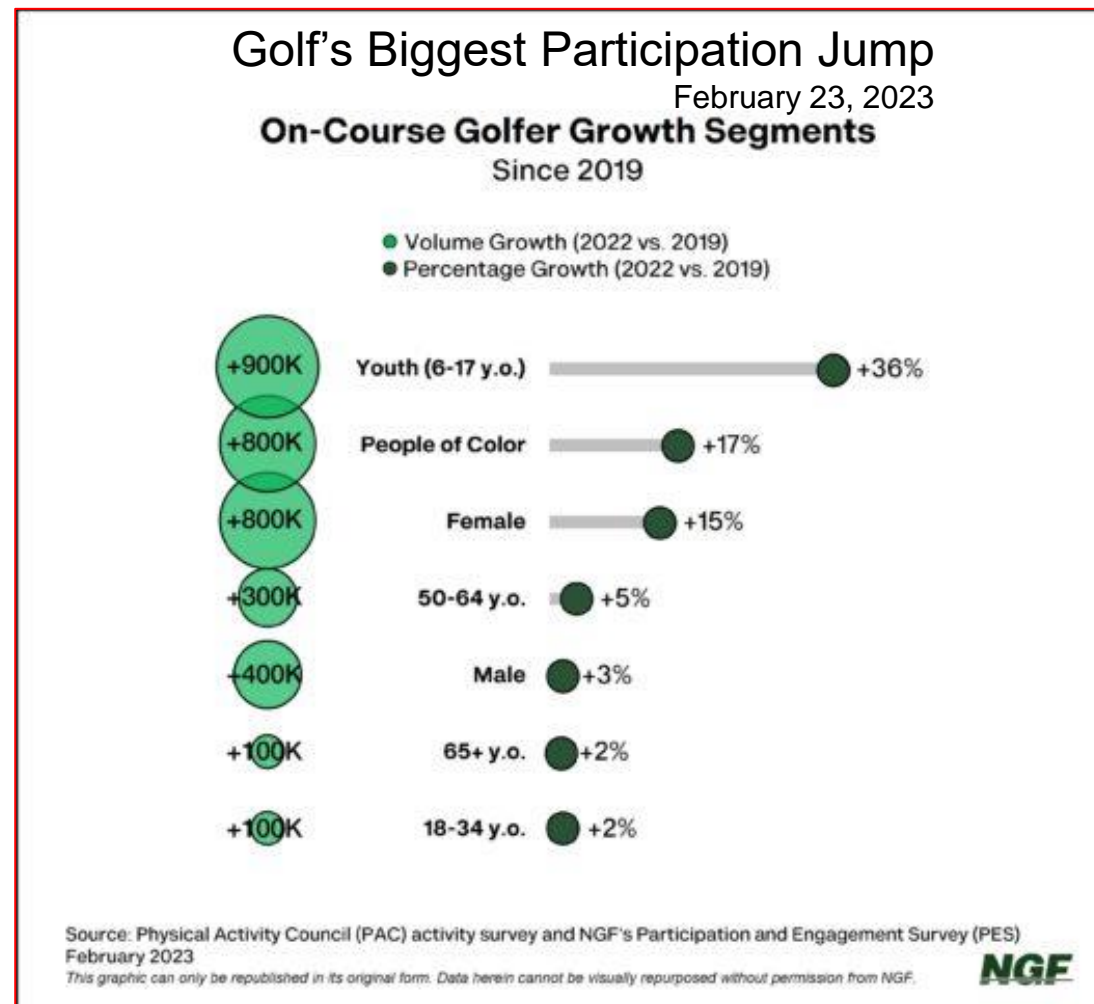



# 高爾夫產業動態

## 全球高爾夫球場分佈與打球人口

## Golf Around the World



GLOBAL

參考資料 (出典: The R&A)

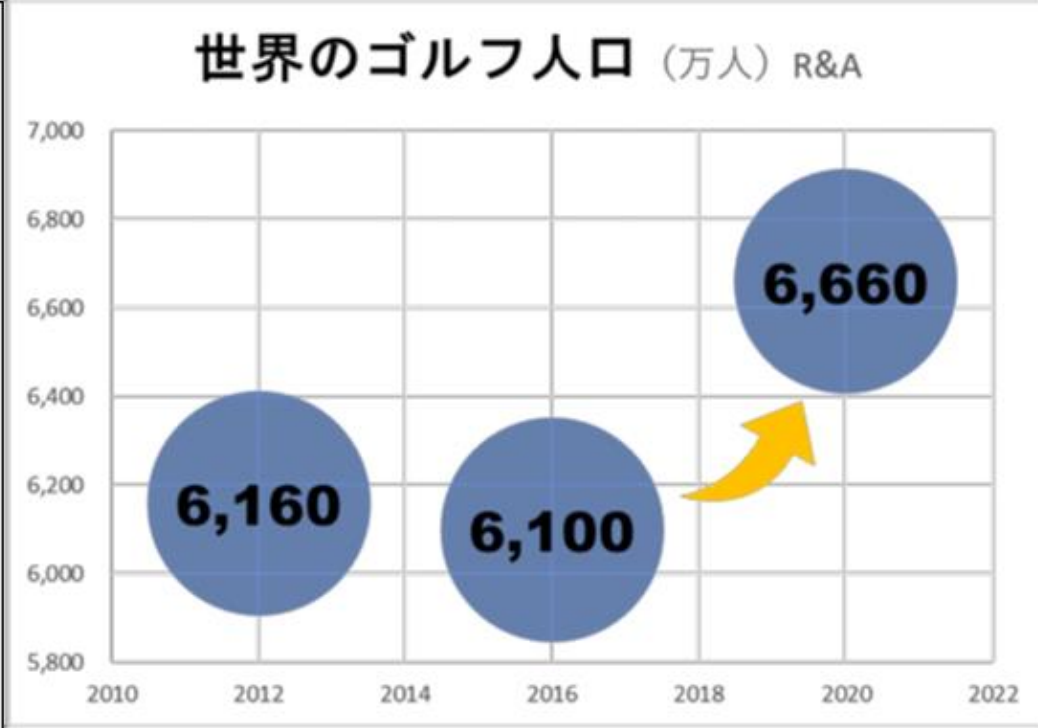
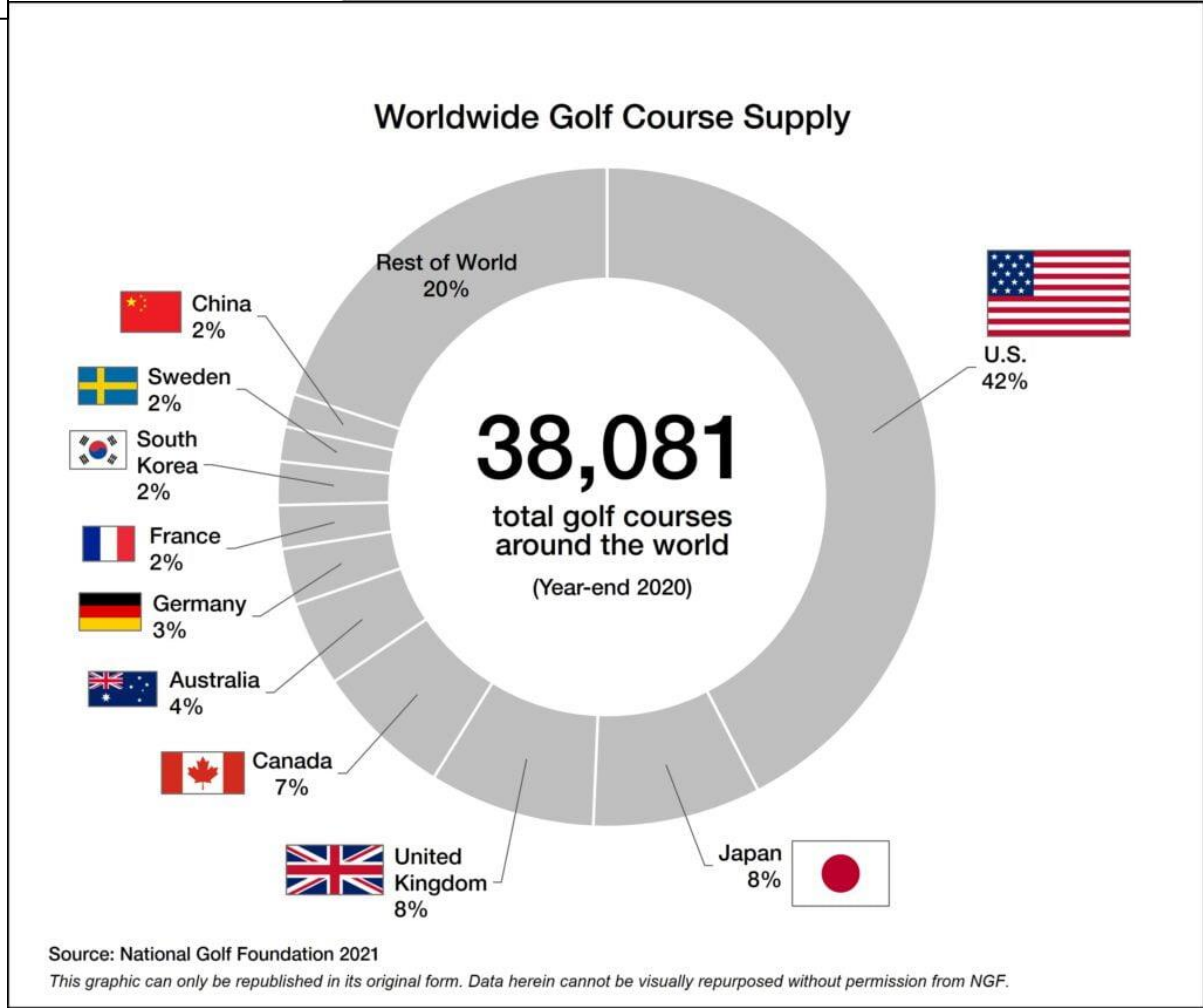

<https://www.prnewswire.com/news-releases/golf-clubs-market-2023-2027-a-descriptive-analysis-of-five-forces-model-market-dynamics-and-segmentation---technavio-301727930.html>



GLOBAL

## Global Golf Clubs Market 2023-2027

## 全球高爾夫球具市場規模2023~2027

### Market Size Outlook (USD Million)

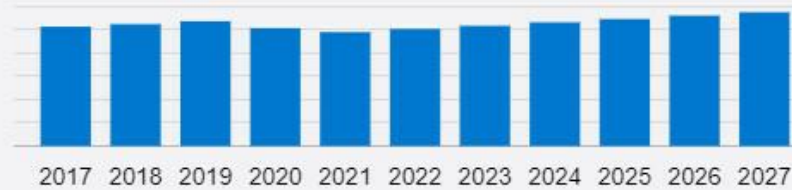

2017 : 5112.04



Year-over-Year growth rate of 2023



CAGR 2022-2027



Growth Momentum



### CUSTOMER LANDSCAPE

- Drivers of price sensitivity
- Adoption lifecycle
- Importance in the customer purchase basket
- Adoption rates
- Key purchase criteria

#### Key purchase criteria



#### Drivers of price sensitivity

Driver	Impact
Purchases are undifferentiated	Low
Purchase is a key cost to the buyer	Low
Quality is not important	Low
Price Sensitivity	High

#### Adoption lifecycle



17000+ Reports covering niche topics. Read them at [technavio](https://technavio.com)



# 美國GOLF市場未來發展: 樂觀可期

<https://www.grandviewresearch.com/industry-analysis/golf-equipment-market>



## U.S. Golf Equipment Market

size, by product, 2020 - 2030 (USD Billion)

### 美國高爾夫用品市場規模

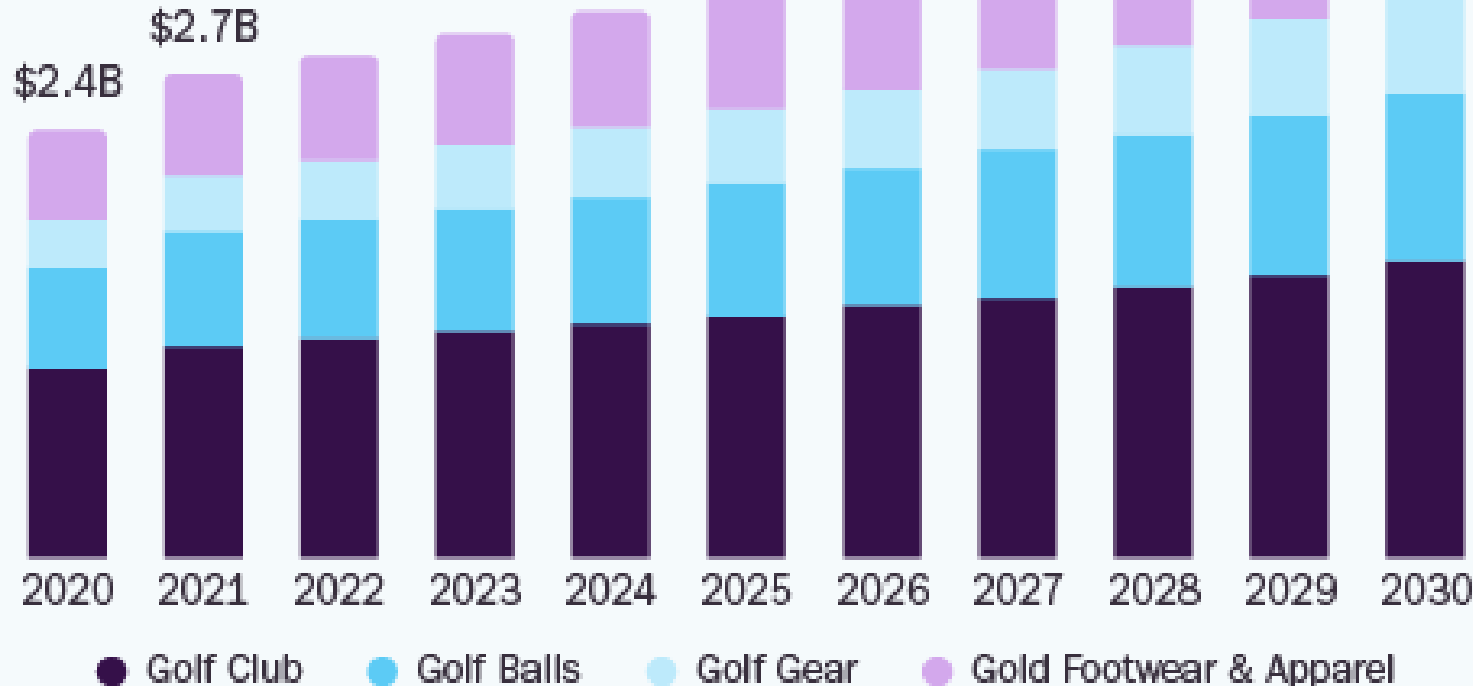

**4.6%**

U.S. Market CAGR,  
2022 - 2030

Source:  
[www.grandviewresearch.com](http://www.grandviewresearch.com)

# 美國GOLF市場未來發展: 樂觀可期

## GOLF打球場次報告

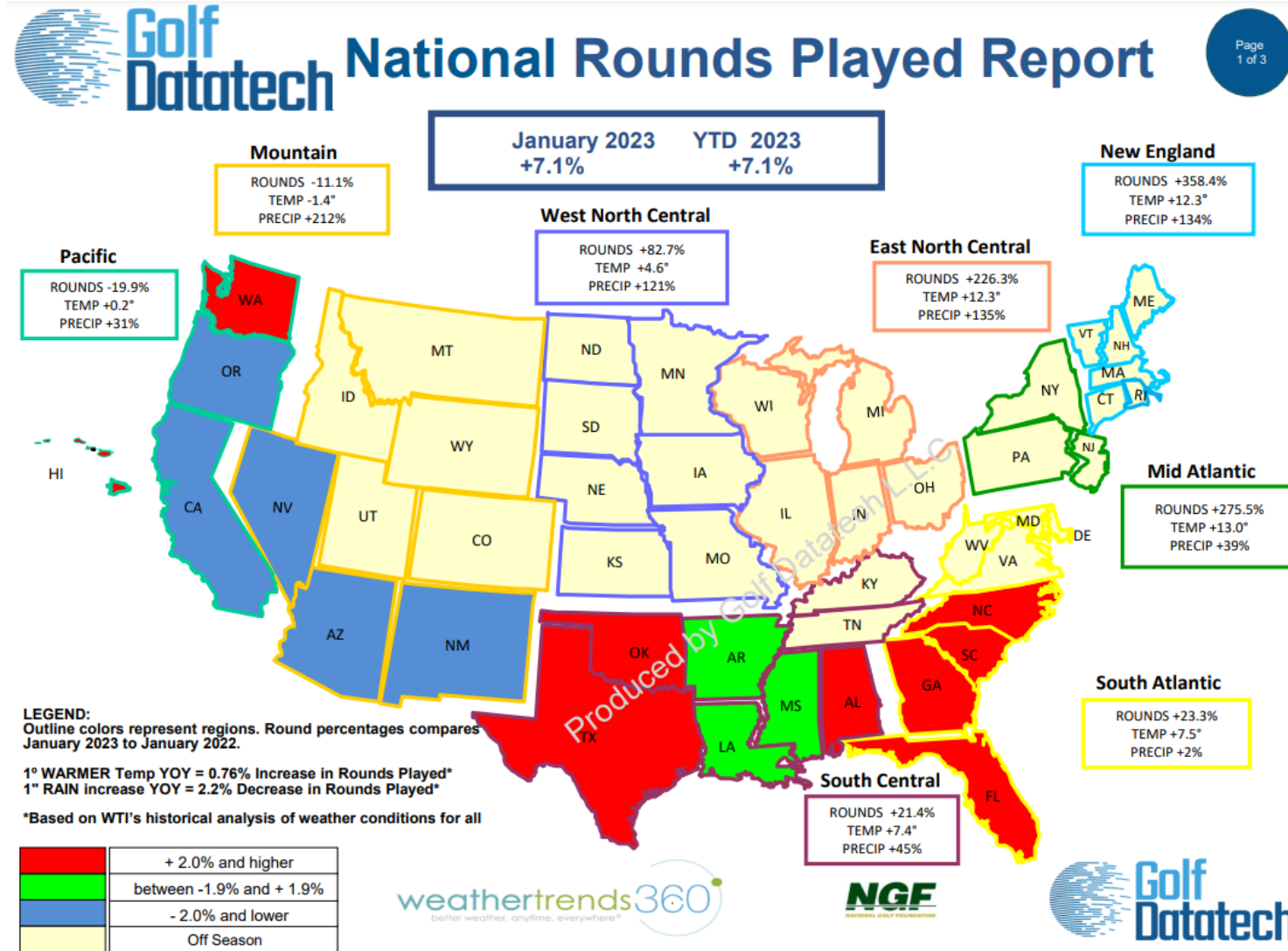





# 日本市場未來發展:樂觀可期

## ✓需求 > 供給

- COVID-19疫情影響，2020年需求大於供給，但難以看出實際對策是否愈嚴，打球人口就會增加
- 價格戰已減少，折扣變少，銷售趨勢為量非高，但價高
- 市售便宜球具↓，貴的↑
- 疫情期間GOLF人口變化：**日本市場多81萬打球人口**，尤其是女性打球者變多→**女性佔40.5%**，過去只有**20%左右**。(GOLF活動非在密閉空間)
- **GOLF人口退出市場的少，增加的人多**，因此需求大於供給。(推算2022年只減少70,560人，過去第一次調查時減少2,646,000人)



# 日本市場未來發展:樂觀可期



✓ 矢野建議如何深根81萬人續打及拉更多新進者：

- **廠商健全收益，取消價格戰，目前商家直營化是趨勢**

- 廠商降低專人服務成本回饋到球員售價，收益有助提高，過去試打要有專人服務，挑球員，現應用網路數據直接就可找出符合個人的球員；

- **「體驗」商機\_GOLF打球旅遊化**

- 安排半天或打球一天的行程，先上課→模擬情境→上場練習→1小時打3洞實際體驗→領小禮物或零食→賦歸。

- **創造機會\_GOLF球場更多人練習，提供免費球員試打，GOLF課程有店面免費試打活動或播放Pro建議影片...等。**

- 個人→休閒、健康、家族...。

資料來源：矢野經濟研究所(是日本具公信力的調研機構)日本COVID-19疫情下的GOLF產業發展說明會



# 未來發展







O-TA GOLF

# Design

研發力 | 生產力 | 軟實力

ESG

環境保護 • 社會責任 • 公司治理



誠信務  
Honesty

- 持續提供客戶協同、  
性能模擬、高附加價  
值的量身訂作之

## 設計製造服務

大田致力於創新及高科技材料與結構設計的研發！  
並要求在事業經營和客戶服務上具有最高的道德標準！



# 大田 成長戰略

# 推進自動化

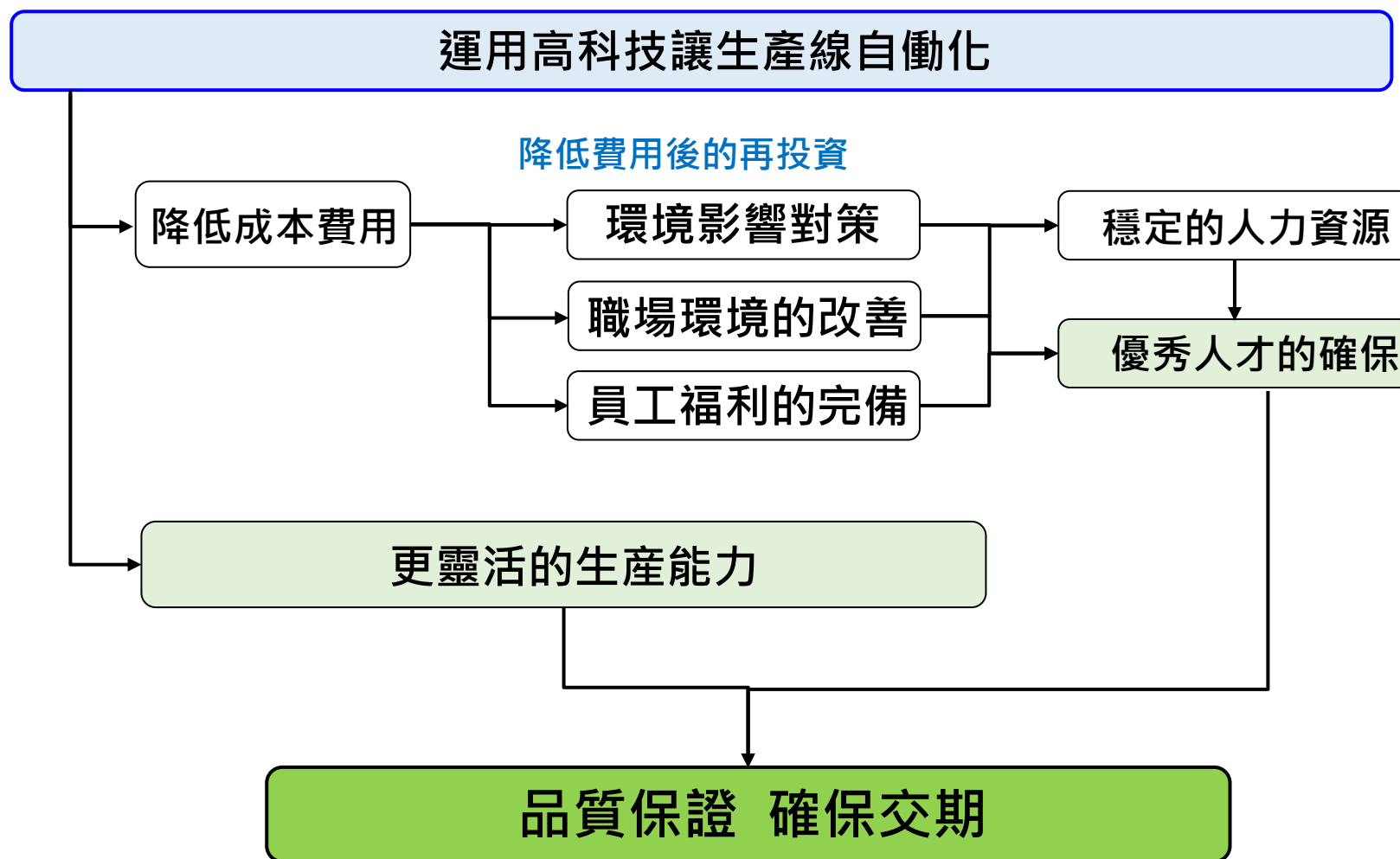

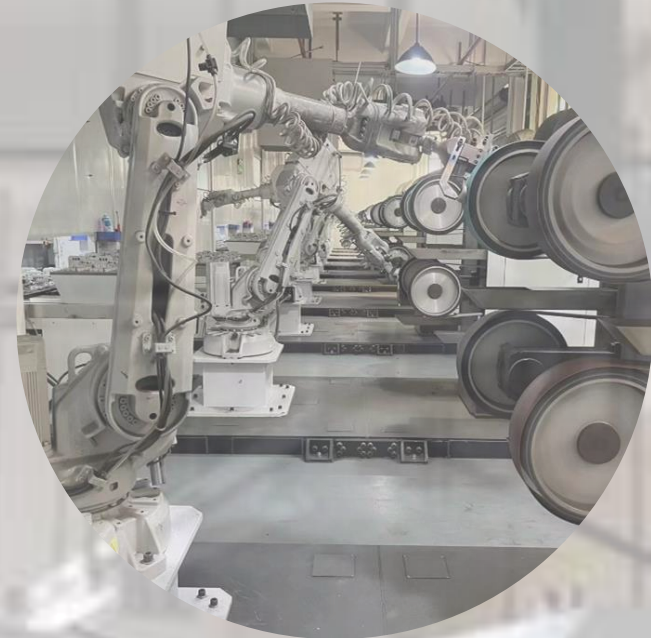

✓ **確保穩定的高毛利！**

精實管理、導入自動化，降低成本，縮短途程、提高效率與效能





# 大田 成長戰略

## Smart Manufacturing 從自働化到自律化



	自働化	自律化
可執行的	根據預先確定的最優條件、連續運行	根據環境和條件的變化更新操作條件，靈活應對
適合工廠的應用	· 可持續生產相同產品的工廠	· 生產項目變化多的工廠 · 可處理產品的形狀和品質不齊的工廠



# R&D\_強調創新，提供高附加價值產品與服務



近期研發成果：

1. 高爾夫球頭新素材
2. 高爾夫球頭新結構、新設計
3. 高爾夫球頭模擬解析系統開發技術
4. 專利：12件發明專利權 + 11件申請案審查中
5. Open model成果分享~~

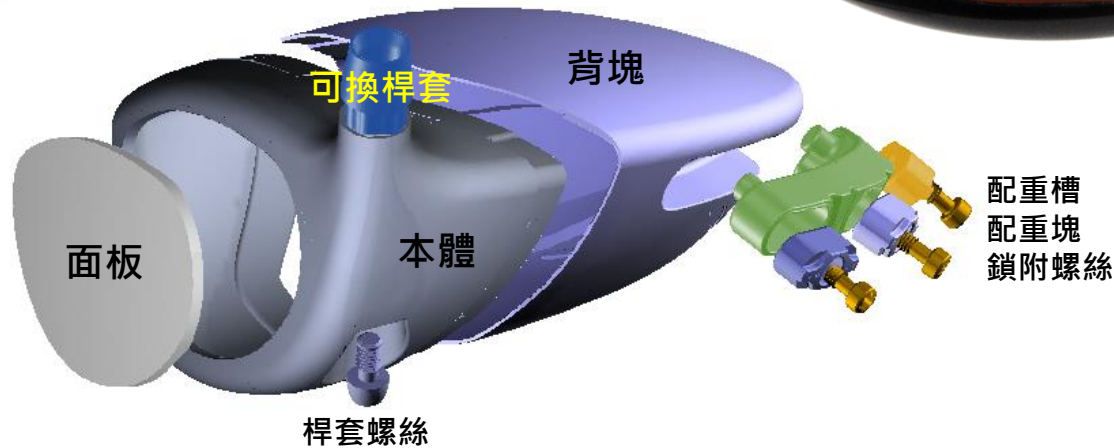
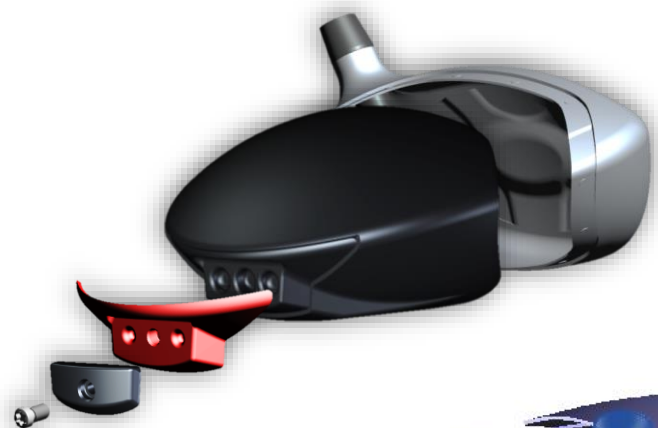





台灣百大品牌  
大田精密工業股份有限公司  
O-TA Precision Industry CO.,LTD.

## 新世代 複合材高爾夫球頭

- 取代「鈦合金」之革命性產品。
- 已取得台灣、日本、美國及中國發明專利。

01. 本體碳纖含桿頭一體成型。



02. 可調/可換桿設計。

03. 異素材結合(金屬/非金屬)。

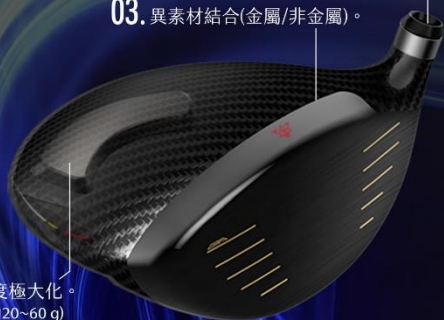

04. 配重設計裕度極大化。  
(約20~60g)

05. 擊球距離更遠 / 打感更好 / 聲響更棒。



屏東縣內埔工業區建富路8號  
(No.8 Chien-Fu Rd, Nei-Pu Industrial Zone, Pingtung County, R.O.C.)  
Phone: +886-8-778-3855 Fax: +886-8-779-2922



台灣百大品牌  
大田精密工業股份有限公司  
O-TA Precision Industry CO.,LTD.

www.o-ta.com.tw



## O-TA GOLF Design

研發力 | 生產力 | 軟實力

ESG

環境保護 · 社會責任 · 公司治理

誠信務實  
Integrity & Pragmatism

研發創新  
Innovative R & D

永續經營  
Sustainable operation



屏東縣內埔工業區建富路8號  
(No.8 Chien-Fu Rd, Nei-Pu Industrial Zone, Pingtung County, R.O.C.)  
Phone: +886-8-778-3855 Fax: +886-8-779-2922





# 大田 ESG 亮點:

- 大田公司**營運穩定**→品牌客戶信賴與肯定→營收NT\$77億元維持高基期→獲利成績亮麗\_稅後淨利NT\$17.93億元、**EPS 21.4元**、純益率23% →**獲利歷史新高紀錄**
- 永續發展委員會
  - 永續環境 社會公益 公司治理 產品責任
- 推動**正向文化 & 藝術美學經營事業**  
關懷 分享 感恩 惜福
- **友善 & 幸福職場**：鼓勵運動 健康促進 享健康 戰疫關懷...
- **太陽能光電停車場**→善用地利與員工福利
- 推動**綠生活**→「低碳、蔬食、節能、減塑、減廢」 環保愛地球 → 綠色消費 → 在地永續&食安的綠色產品
- **節能減碳措施**：
  - ✓ **綠色研發 & 生產**→研發與全製程→「減量、回收、替代」→節省耗能、減少排碳、降低污染
  - ✓ **節能管理**：使用節能燈具、辦公室無紙 E 化、省電節能設備，午休時間熄燈節能
- **在地永續**：當地採購率70%以上、江西在地員工80%

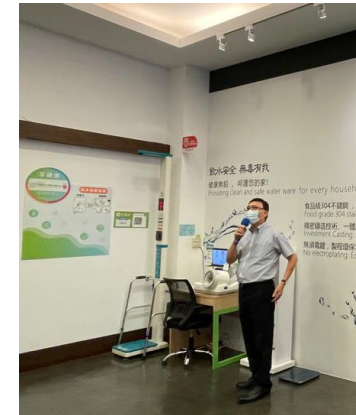

TOP 100



台灣百大品牌

大田精密工業股份有限公司

O-TA Precision Industry CO.,LTD.

## 綠色生活

環保愛地球，節能減碳，人人皆可做~



精實管理、降低成本、提高性能、客戶滿意







*Thanks for your attention*

簡報完畢，恭請指教

